

PRODUCT FLYER

mmWave Transceiver System

CONTENTS

[mmWave Transceiver System](#)

[Detailed View of Example MTS Configuration](#)

[Key Features](#)

[5G New Radio Physical Layer Software Reference Designs](#)

[NI-mmWave Application Programming Interface \(API\)](#)

[Unparalleled Solutions for SDR](#)

[NI SDR Hardware](#)

[Hardware Services](#)

mmWave Transceiver System

Model page



- **Software:** Includes API support for LabVIEW and LabVIEW FPGA, sample streaming project, and detailed help files
- 2 GHz real-time bandwidth throughout the entire system
- Modular radio heads with support for the following frequency bands:
 - 24.25 - 33.4 GHz
 - 37 - 42.5 GHz
 - 71 - 76 GHz
- Base configurations for bidirectional and unidirectional systems that scale from SISO to MIMO

A High Performance SDR for mmWave

The mmWave Transceiver System (MTS) is a software defined radio (SDR) that was designed with 5G in mind. It has 2 GHz of real-time bandwidth that can be used to create over-the-air prototypes of 5G New Radio (NR) communications links. A multi-FPGA processing architecture makes it possible to both capture or generate 2 GHz of data and also process the data in real time. This is key for creating an over-the-air communications system with no offline processing needed.

The MTS is a modular system that can be configured a number of different ways to meet a variety of use cases. Each different configuration is built from a common set of hardware, the PXIe-3610 DAC, the PXIe-3630 ADC, and the PXIe-3620 LO and IF module. Each PXIe-3610 and PXIe-3630 is paired with a PXIe-7902 FPGA. Outside of the PXI chassis, the MTS can be connected to a mmRH-364x transmitter, a mmRH-365x receiver, or a mmRH-360x transceiver. This allows for maximum hardware and software reusability for use in different frequency bands.

In addition to the RF hardware in the MTS, it is common for additional FPGAs to be added to the system for real-time processing. One example application that needs additional FPGAs is a real-time 5G NR physical layer. For a communications link to be able to calculate data throughput, the signal must be encoded and decoded in real time. Decoding is very processor intensive and requires additional FPGAs. A PXIe-6674T timing and synchronization module is another typical addition to the base configuration of MTS. This module provides a trigger that can be used to synchronize multiple channels for MIMO configurations, and it provides a higher quality 10 MHz clock source for better overall RF performance.

Table 1. An overview of the modular mmWave radio heads offered by NI and required digital cables for each model

	24.25-33.4 GHz	37-42.5 GHz	71-76 GHz
Transmit only mmRH	mmRH 3642	mmRH 3643	mmRH 3647
Receive only mmRH	mmRH 3652	mmRH 3653	mmRH 3657
Transceiver mmRH	mmRH 3602	mmRH 3603	-
Digital Cable Required	785811-01	785811-01	784577-01 (Single radio head) 784579-01 (Dual radio heads)

Detailed View of Example MTS Configuration

Single Bidirectional Channel with 5G NR Coding FPGAs

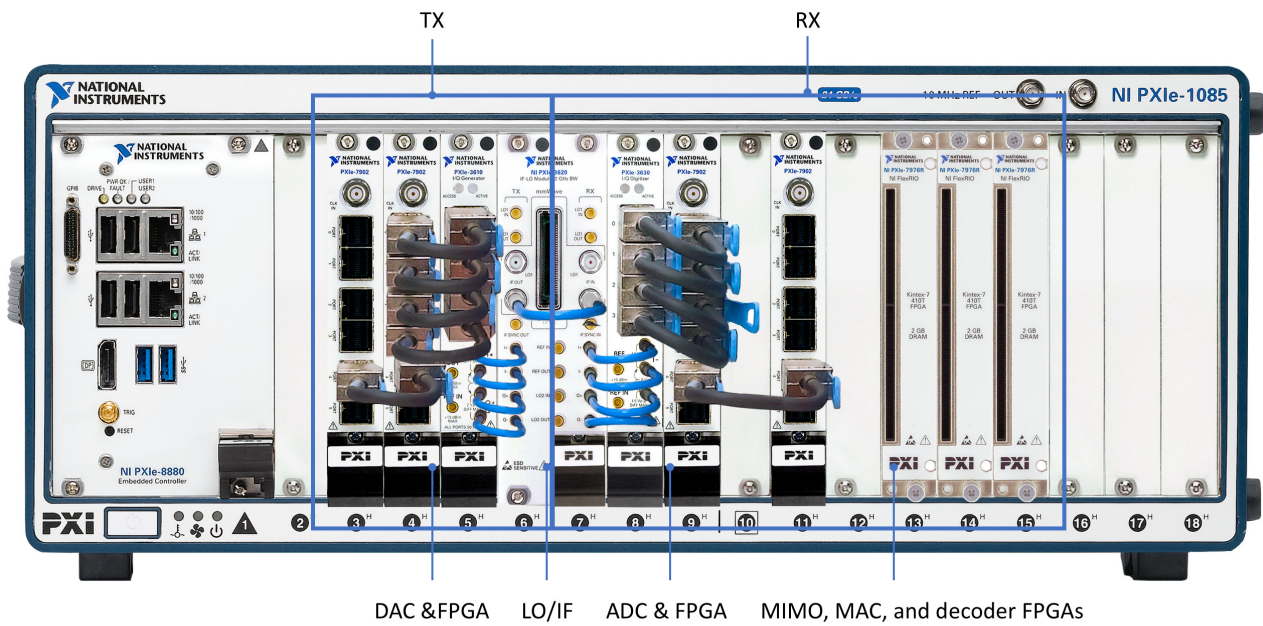

Figure 1. One channel of a bidirectional SISO system with additional FPGAs for real-time coding

Key Features

Modular Configurations

The mmWave Transceiver System's modular design supports a variety of configurations to enable numerous different kinds of wide bandwidth mmWave applications. The MTS can be purchased as a bundle, or a custom configuration can be assembled from the individual modules in the system. The bundles each consist of two systems, just like a communications link. There is an option for unidirectional systems with a transmit system and a receive system. This type of system is ideal for downlink only communications links. The other option is a bidirectional system, which is built from two transceiver systems and can be used for both uplink and downlink communications systems. There are single-channel (SISO) and two-channel (MIMO) options for both configurations available. The image above shows an example of one of the two systems included in the bidirectional SISO bundle. Additional FPGAs have been added to the system above, which are used for additional real-time processing.

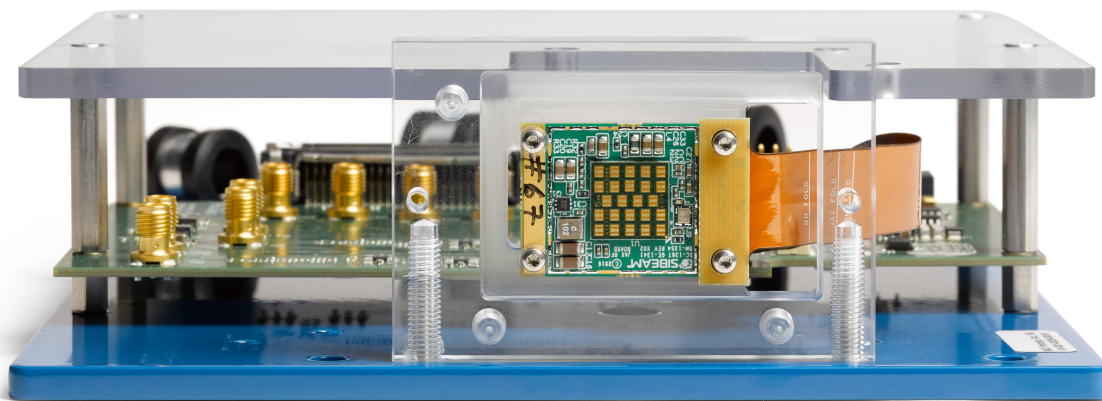

Figure 2. 60 GHz RFIC with integrated antenna and interposer board. This interposer board can be used to connect the RFIC to the MTS baseband.

The MTS is modular and reconfigurable in other ways as well. The bundles mentioned above include the baseband and IF hardware. Millimeter wave radio heads (mmRHs) are then added to the system. NI currently offers mmRHs covering three frequency bands which are aligned to the 3GPP's 5G specification. The MTS will work using NI's baseband, IF, and mmWave radio heads, but it also will work with just NI's baseband and IF or with just NI's baseband. This allows users to connect RFICs, 3rd party radio heads, or other custom mmWave hardware to the MTS and take advantage of the software benefits that LabVIEW offers.

Parallel Processing

The MTS is capable of not only streaming 2 GHz of bandwidth per channel in real time, but also processing these 2 GHz channels in real time using LabVIEW FPGA, parallel processing, and a multi-FPGA architecture. In most FPGA processing, the clock rate of the FPGA drives the rate at which data can be processed. For example, a typical FPGA clock rate is 192 MHz, where 192 MS/s can be processed. In order to process up to 2 GS/s, the received data must be split into 192 MS chunks, processed, and recombined while maintaining data integrity. Even relatively simple processing tasks like computing an FFT using pre-built Xilinx IP requires extra effort. For the case of processing an FFT, the Cooley-Tukey method can be used to apply twiddle factors. Figure 3 shows the LabVIEW FPGA code used for this process to take 16 samples at a time and process the full 2 GHz of bandwidth.

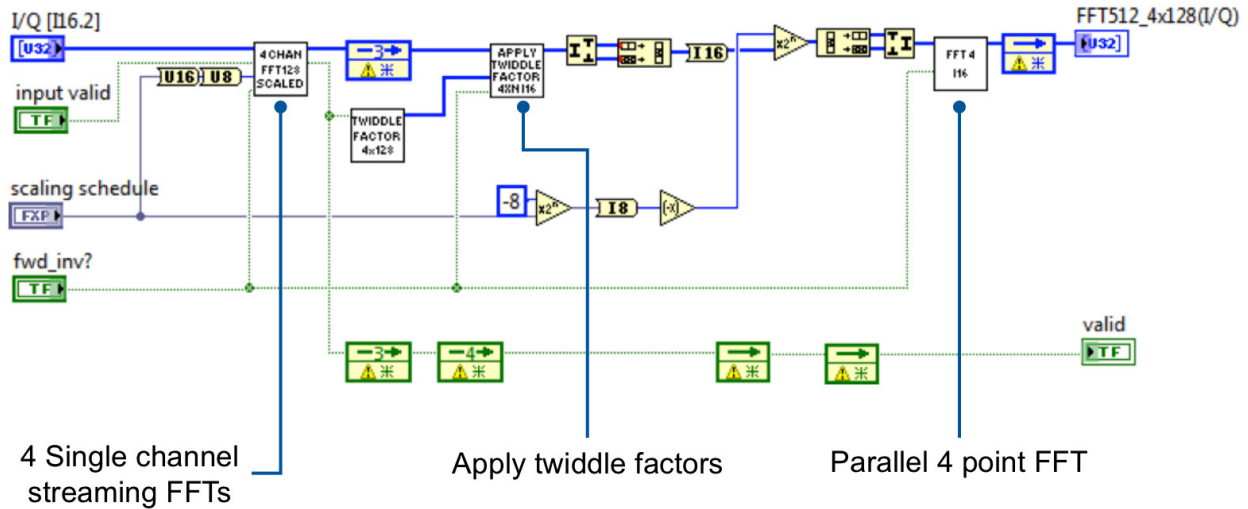

Figure 3. Cooley-Tukey multi-sample FFT in LabVIEW FPGA

Multi-FPGA Architecture

In addition to using parallel processing to process large amounts of raw data, multiple FPGAs are also used to build the processing used in highly complex wireless communications systems. Specifically, the 5G New Radio (5G NR) standard for mmWave frequencies uses a combination of computationally intensive algorithms to encode, decode, modulate, demodulate, and multiplex signals in the physical layer. The physical (PHY) layer and portions of the MAC layer need to be processed in less than one subframe, on the order of nanoseconds, for the system to be able to behave as a real-time communications system and to create a successful wireless link. Figure 4 shows a high-level block diagram of different computational blocks and where the processing occurs inside of a 5G NR communications link.

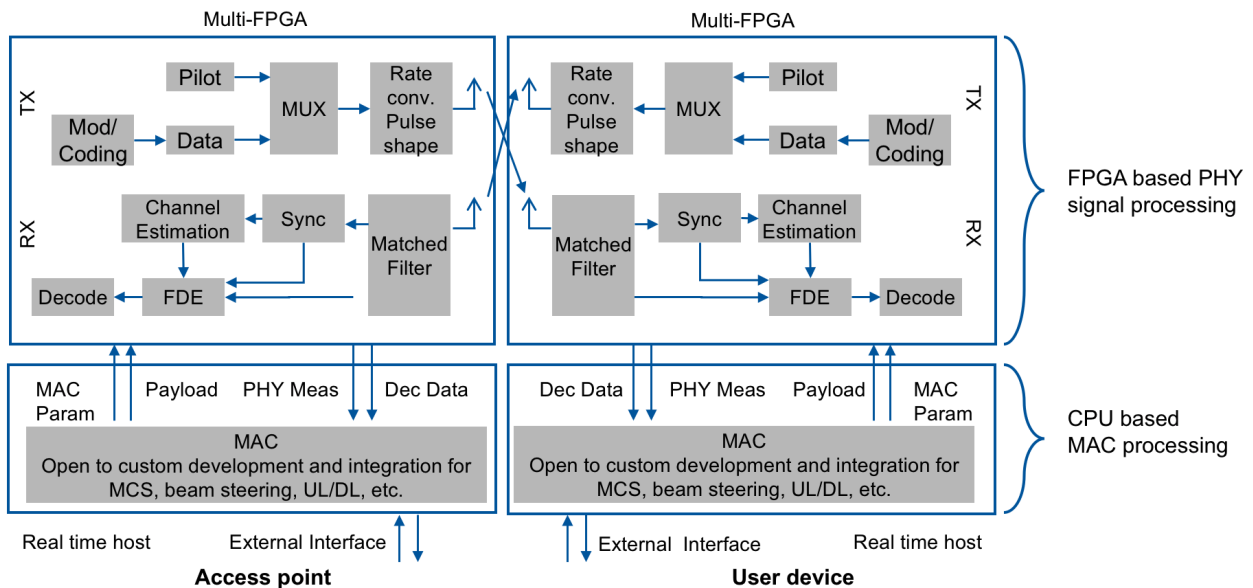

Figure 4. 5G NR PHY and MAC layer processing block diagram

5G New Radio Physical Layer Software Reference Designs

One of the key applications the mmWave Transceiver System serves is prototyping over-the-air communications links for advanced wireless research, like 5G New Radio. To give researchers an out-of-the-box starting point, NI has developed two 5G NR physical layer reference designs—one based on the 5G NR phase 1 specification that uses OFDM and a second based on the 5G NR phase 2 specification that uses a single carrier modulation scheme. These reference designs use the MTS plus additional processing FPGAs and timing and synchronization modules (as shown in Figure 1). The reference designs are delivered as source code and are completely open and modifiable to provide the greatest amount of flexibility for wireless communications research.

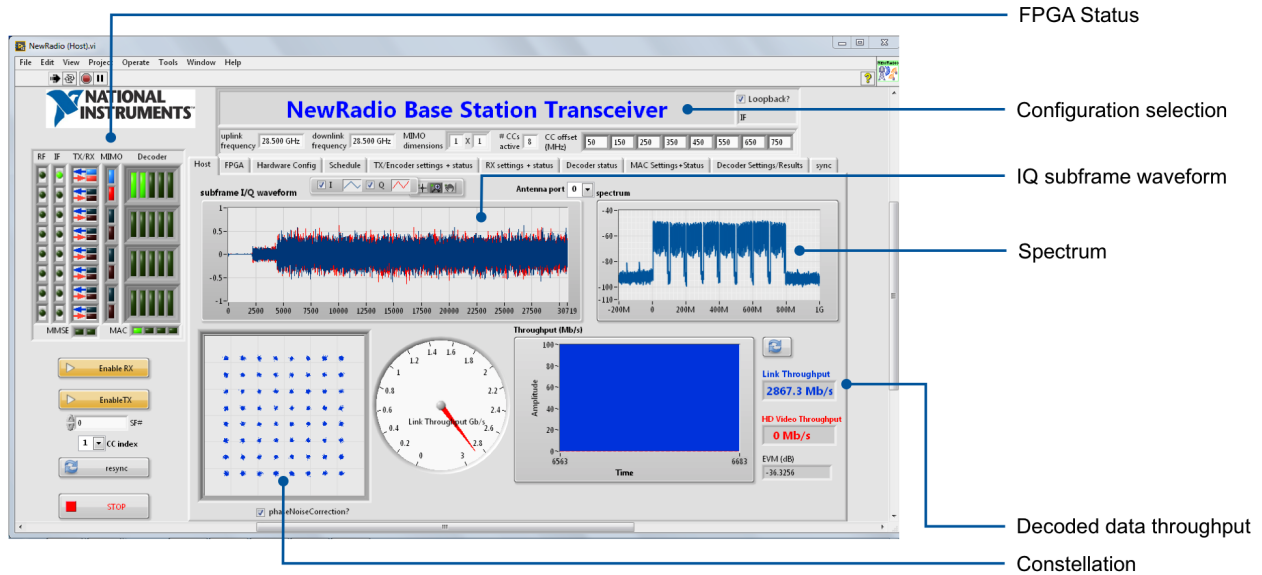

Figure 5: 5G New Radio phase 1 reference design front panel

NI-mmWave Application Programming Interface (API)

The NI-mmWave driver includes a best-in-class API that works with LabVIEW and LabVIEW FPGA. The driver provides access to help files, documentation, self-test VIs, and ready-to-run sample streaming projects you can use as a starting point for your application. Like the driver for other NI reconfigurable I/O products, the NI-mmWave sample streaming project includes software that runs on the host and software that runs on the FPGA. A snippet of the host-based API can be seen below in Figure 6.

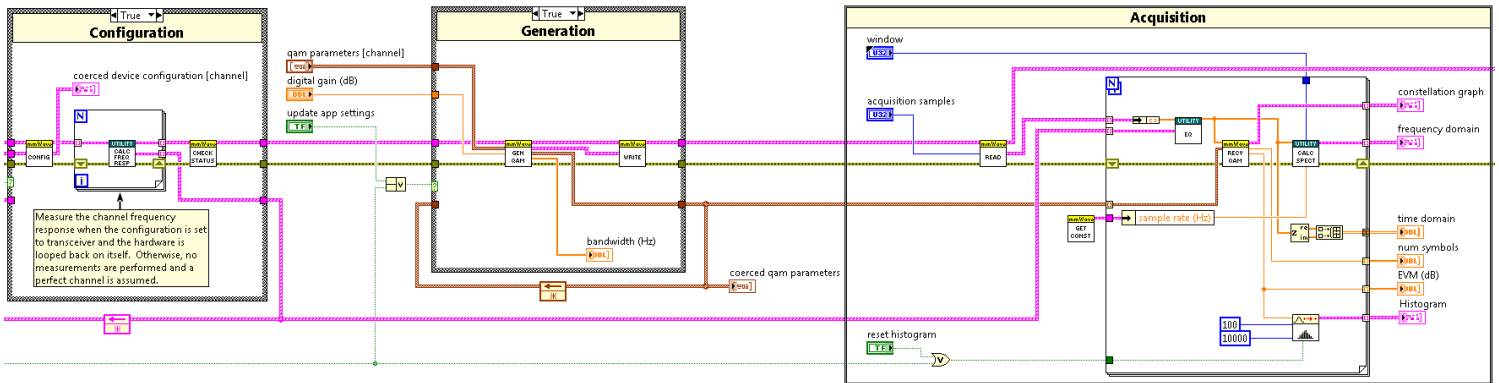

Figure 6: Snippet of NI-mmWave driver host-based API

Unparalleled Solutions for SDR

NI SDR hardware and software solutions drive productivity, shorten time to results, and empower engineers, scientists, and researchers to design next-generation wireless technologies.

The breadth and depth of NI's SDR offering are unrivaled. Scaling from small to massive, NI SDR tools, including those from Ettus Research, an NI company, can be used for a wide variety of applications including signals intelligence, military communications, radar, and communications research.

Across applications and industries like these, wireless researchers can leverage NI tools that scale from cost-effective single-user experimentation systems to densely packed Massive MIMO systems capable of accommodating hundreds of radios and antennas. And when it comes to software, NI provides unmatched flexibility and choice from the simplified FPGA programming of the LabVIEW Communications System Design Suite to a wide, vibrant community of open-source software contributors through GNU Radio.



NI SDR Hardware

NI offers the most comprehensive range of SDR hardware in the world. With banded frequency options from DC to 71 GHz, up to 2 GHz of real-time bandwidth, powerful DSP-focused FPGAs, and form factors ranging from handheld devices to high-channel-count systems, NI SDRs can meet your needs from design to deployment.



B Series/USRP-290x

Cost-effective USB SDR with a wide frequency range, a compact form factor, and up to 15 MHz of streaming bandwidth



N Series/USRP-292x

High-value Ethernet-connected USRP featuring superior RF performance, MIMO capability, and up to 100 MHz of bandwidth



E Series

Portable and stand-alone wideband SDR containing a Zynq SoC, a 2x2 MIMO transceiver, and 56 MHz of bandwidth



X Series/USRP RIO

High-performance PCI Express/10 Gigabit Ethernet, including a powerful Kintex-7 FPGA, a 2x2 MIMO transceiver, and up to 160 MHz of bandwidth

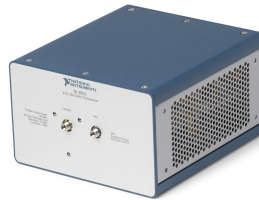

mmWave Transceiver System

Advanced multi-FPGA solution for real-time 5G prototyping that features 2 GHz of bandwidth at the 28, 39, and 73 GHz bands



ATCA-3671

Four Virtex-7 690T FPGAs in an ATCA form factor, dedicated internal serial links between each FPGA, and up to 160 GB/s of external digital connectivity



Stand-alone SDR

High-performing SDR with an on-board processor and FPGA for stand-alone applications, up to 160 MHz of bandwidth, and MIMO capability.

Ettus Research, an NI company, hosts detailed product information for B Series, N Series, E Series, and X Series products online at ettus.com.

Hardware Services

All NI hardware includes a one-year warranty for basic repair coverage, and calibration in adherence to NI specifications prior to shipment. PXI systems also include basic assembly and a functional test. NI offers additional entitlements to improve uptime and lower maintenance costs with service programs for hardware. Learn more at ni.com/services/hardware.

	Standard	Premium	Description
Program Duration	1, 3, or 5 years	1, 3, or 5 years	Length of service program
Extended Repair Coverage	•	•	NI restores your device's functionality and includes firmware updates and factory calibration.
System Configuration, Assembly, and Test ¹	•	•	NI technicians assemble, install software in, and test your system per your custom configuration prior to shipment.
Advanced Replacement ²		•	NI stocks replacement hardware that can be shipped immediately if a repair is needed.
System Return Material Authorization (RMA) ¹		•	NI accepts the delivery of fully assembled systems when performing repair services.
Calibration Plan (Optional)	Standard	Expedited ³	NI performs the requested level of calibration at the specified calibration interval for the duration of the service program.

¹This option is only available for PXI, CompactRIO, and CompactDAQ systems.

²This option is not available for all products in all countries. Contact your local NI sales engineer to confirm availability.

³Expedited calibration only includes traceable levels.

PremiumPlus Service Program

NI can customize the offerings listed above, or offer additional entitlements such as on-site calibration, custom sparring, and life-cycle services through a PremiumPlus Service Program. Contact your NI sales representative to learn more.

Technical Support

Every NI system includes a 30-day trial for phone and e-mail support from NI engineers, which can be extended through a [Software Service Program \(SSP\)](#) membership. NI has more than 400 support engineers available around the globe to provide local support in more than 30 languages. Additionally, take advantage of NI's award winning [online resources](#) and [communities](#).

©2018 National Instruments. All rights reserved. LabVIEW, National Instruments, NI, NI TestStand, and ni.com are trademarks of National Instruments. Other product and company names listed are trademarks or trade names of their respective companies. The contents of this Site could contain technical inaccuracies, typographical errors or out-of-date information. Information may be updated or changed at any time, without notice. Visit ni.com/manuals for the latest information.

21 June 2018